

KNIFE GATE VALVE



SCI Knife Gate Valves are designed to provide reliable service in tough abrasive and corrosive slurry applications, suitable for powder, slurry, pulp and paper industry. The unique design provides easy operation together with low maintenance and long lasting valve life.

FEATURES

- Replaceable packing without valve disassembly.
- Bi-directional sealing design.
- Cast iron split Body with Body Seat.
- Four Pillars arrangement provides stability from heavy operation.
- Stainless steel gate provides corrosion resistance.
- Stainless steel stem provides durable and easy operation.
- International standard flanges are provided. (please specify)

DESIGN SPECIFICATIONS

- Size: 50 mm to 300 mm
- Working pressure: 10, 16 Bar
- Working temperature: NBR up to 80°C, EPDM up to 110°C
- Shell test: 1.5xPN
- Seat test: 1.0xPN
- Fusion bonded epoxy coating. Other coatings are available.
- Actuator type : Handwheel, Chainwheel, Gear, Cylinder or Electric motor.

DIMENSIONS AND MATERIALS

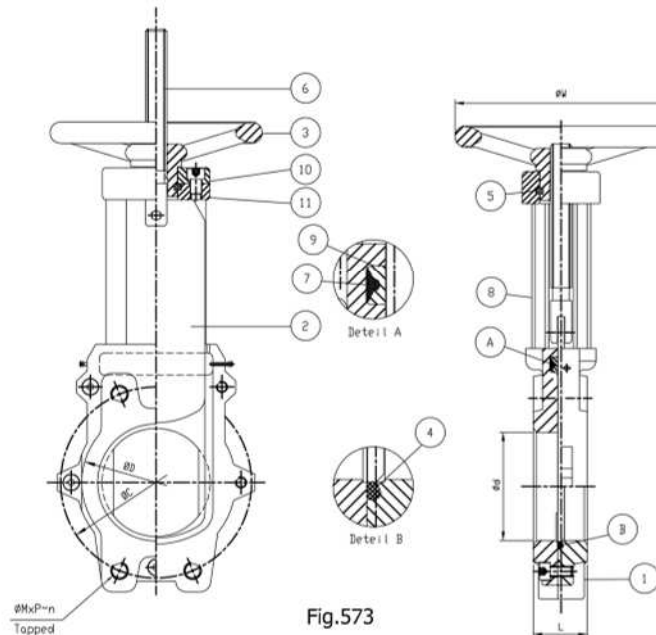

NO.	PARTS	MATERIAL	BS.SPEC.
1	Body	Cast Iron	EN 1561-EN-GJL-250
		Ductile Iron	EN 1563-EN-GJL-500-7
2	Gate	Stainless Steel	EN 10088 Grade.1.4301 EN 10088 Grade.1.4401
3	Hand Wheel	Cast Iron	EN 1561-EN-GJL-200
4	Body Seat	Rubber(NBR)	EN 681-1
		Rubber(EPDM)	
5	Thrust Washer	High Tensile Brass	EN 12165-CW721R EN 10088 Grade.1.4301 EN 10088 Grade.1.4401
6	Stem	Stainless Steel	EN 10088 Grade.1.4057
			EN 10088 Grade.1.4021
7	Packing	Non Asbestos	
8	Pillar Tie Rod	Steel	1506
9	Disc Seat	Rubber(NBR)	EN 681-1
		Rubber(EPDM)	
10	Top Plate	Cast Iron	EN 1561-EN-GJL-250
		Ductile Iron	EN 1563-EN-GJL-500-7
11	Bottom Plate	Cast Iron	EN 1561-EN-GJL-250
		Ductile Iron	EN 1563-EN-GJL-500-7

VALVE SIZE	Ød	L	ØD	Flanged tapping BS.EN1092-2				n	ØW
				PN 10		PN 16			
				ØC	ØMxP	ØC	ØMxP		
50	51	40	90	125	16x2	125	16x2	4	200
65	66	48	100	145	16x2	145	16x2	4	200
80	82	51	116	160	16x2	160	16x2	4	200
100	101	51	140	180	16x2	180	16x2	4	200
125	127	57	170	210	16x2	210	16x2	4	250
150	154	57	200	240	20x2.5	240	20x2.5	4	250
200	203	70	250	295	20x2.5	295	20x2.5	4	315
250	255	70	310	350	20x2.5	355	24x3	4	395
300	305	76	370	400	20x2.5	410	24x4	4	395



SCI CORPORATION Co.,Ltd.

Factory: 1/12 Moo 2, Samutsakorn Industrial Estate, Soi 7,
 Rama 2 Road, Tahsai, Muang, Samutsakorn 74000, Thailand
 Tel: (6634)440-130 Fax: (6634)440-137 E-mail: sci@scivalve.com



ISO 9001:2015
 File No.438881 QM
 ISO 14001:2015
 File No.438881 UM